

AD 2000 iQ

Advantage

The AD 2000 iQ's technology delivers superior and measurable performance, ensuring airflow and filtration is maintained even when particulates start to build up. It's thanks to the vacuum/pressure which is three times greater than that of its predecessor, the AD 2000. This makes it suitable for the most demanding and complex installations, so you can rely on extended filter life, together with effective removal of fumes and particulates.

It's user friendly too, with a design that makes easy work of filter changes. And the easy to read and access controls display panel is conveniently located on top of the unit. The iQ Operating System is Patent-protected and has received global acclaim for its ability to maximise manufacturing performance and continuity of production.

The AD 2000 iQ's design also permits greater flexibility of different exhaust installations. Different exhaust configurations allow recirculation via the rear panel or externally vented hose connection systems.

STANDARD FEATURES:

- iQ Operating System
- 2 x DeepPleat DUO pre filters
- Reverse Flow Air technology
- Combined HEPA/Gas filter incorporating ACF technology
- Blowers with high airflow and vacuum levels
- High contrast display
- Real time airflow reading
- Filter status warnings
- Remote data diagnostics via USB
- Independent filter condition monitoring
- Long life filters with low replacement costs
- 'Run safe' operation (filters must be installed correctly for the unit to operate)

OPTIONAL FEATURES:

- Remote stop / start interface
- Filter change / System fail signal
- VOC gas sensor (Volatile Organic Compound)
- On-board compressor

The AD 2000 iQ laser fume extraction unit packs a heavyweight punch with unsurpassed filter capacity and high performance.

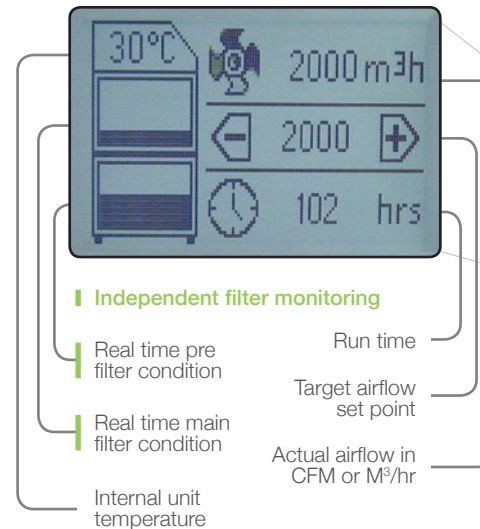

Take a look at the iQ animation, which explains exactly why the patented BOFA iQ Operating System provides unrivalled control and data management for your fume extraction unit.

Patented Technology - Patent No: GB2 499 812

UNIT - PART NUMBERS				
Model	Part No.	24V Stop / Start	Filter change / System failure signal	VOC Monitor
AD 2000 iQ Powder Coated	L5244	A2001	A2002	A2003

REPLACEMENT FILTERS - PART NUMBERS		
Model	Twin Pack DeepPleat DUO Pre Filters	Twin Pack Combined HEPA/Gas Filters
AD 2000 iQ	A1030336	A1030335

TECHNICAL DATA	
	170 - 440V
Dimensions (HxWxD)	1277 x 1318 x 1013mm (50.3 x 51.9 x 39.9")
Cabinet Construction	Powder coated mild steel
Airflow / Pressure	2200m³/hr / 96mBar (1295cfm / 96mBar)
Electrical Data	(EU) 415V / 3Ph / 50Hz / 6.6kw / 16A / L1, L2, L3 14A - N 28A (USA) 208V / 3Ph / 60Hz / 6.6kw / 20A / L1, L2, L3 24A - N 35A
Noise Level	< 62dBA*
Weight	340kgs (750lbs)

* At typical operating speed.

2 X DEEPPLEAT DUO PRE FILTER SPECIFICATIONS	
Surface Media Area	30m² approx (60m²)
Filter Media	Glass Fibre
Filter Media Construction	Maxi Pleat Construction with Webbing Spacers
Filter Housing	Zintec mild steel
Filter Efficiency	F8 (95% @ 0.9 microns)

2 X COMBINED HEPA/GAS FILTER SPECIFICATIONS	
Surface Media Area	7.5m² approx (15m²)
HEPA Filter Media	Glass Fibre
HEPA Media Construction	Maxi Pleat Construction with Webbing Spacers
Filter Housing	Zintec Mild Steel
Treated Activated Carbon	34kgs (68kgs)
Filter Efficiency	99.997% @ 0.3 microns

AIRFLOW THROUGH FILTERS

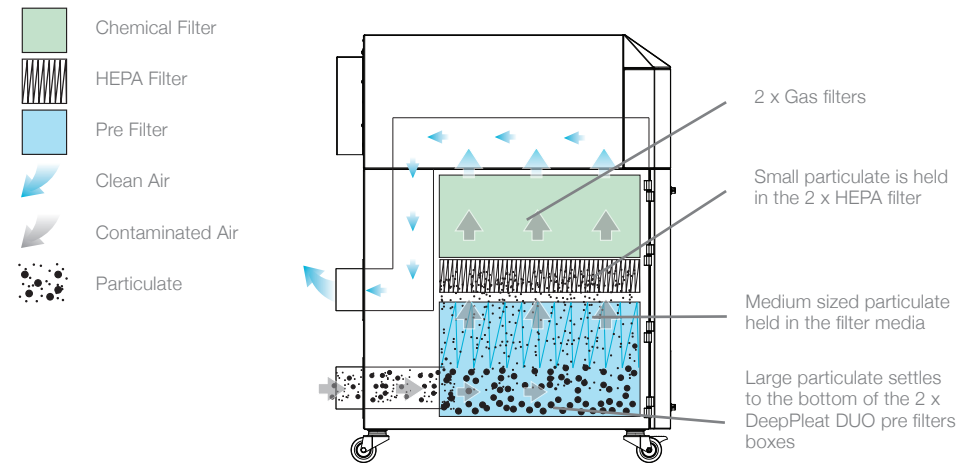

TECHNICAL SPECIFICATION



- iQ Display
- Standby button
- Signal / Interface Cable
- Power Cable
- Locking Castors
- Door Hinges
- Hose Inlet Connections - 125mm
- Optional Exhaust Outlet Connections - 125mm
- Removable front panel
- Door Latches
- On / Off Switch

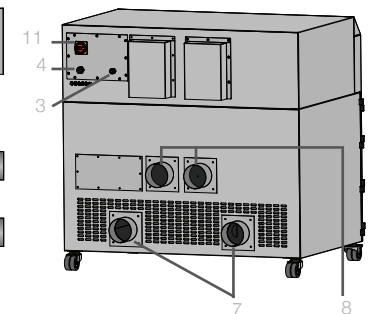
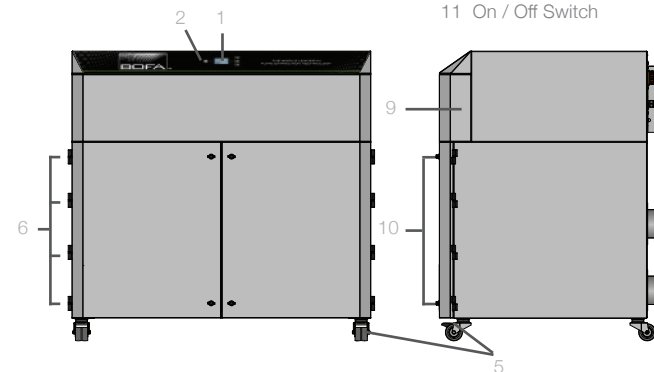

Other hose kits and filters are available. All the above units are fitted with our standard filter combinations. For specific applications please call us for details. Replacement filters should always be ordered using the part number on the filters inside your extractor to ensure the correct filter is ordered. Datasheet correct at time of print.

Date:20/1/15 V:1.4



BOFA INTERNATIONAL LTD

Tel: +44 (0) 1202 699 444 Fax: +44 (0) 1202 699 446 Email: sales@bofa.co.uk Web: www.bofa.co.uk

BOFA AMERICAS, INC

Tel: (618) 205 5007 Fax: (866) 707 2632 Email: sales@bofaamericas.com Web: www.bofaamericas.com



British Quality

